

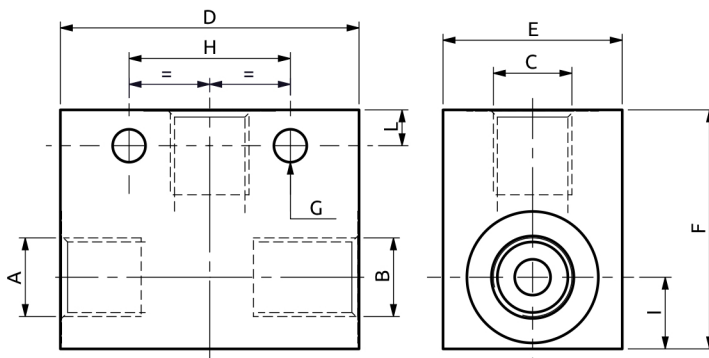

Valvola selettiva Shuttle valve

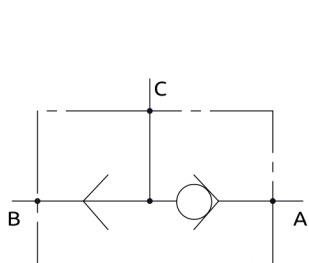

CURVE CARATTERISTICHE
PERFORMANCE CURVES

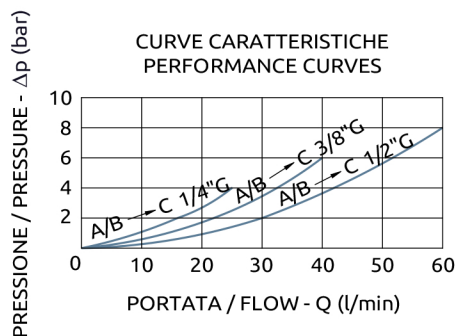

Corpo in acciaio / Steel body

A100202.02.00	FEMMINA/FEMALE	1/4"G	50	30	40	6.5	27	12	6
A100302.01.00	FEMMINA/FEMALE	3/8"G	70	35	50	6.5	45	16	8
A100402.01.00	FEMMINA/FEMALE	1/2"G	70	30	50	9	40	16	13
COD.	PORTS TYPE (A,B)	A/B/C	D	E	F	G	H	I	L



DESCRIZIONE

La valvola invia all'attacco C la maggiore tra le due pressioni presenti sui rami A e B e bloccano la via verso il ramo a pressione minore. Generalmente utilizzata per lo sblocco dei freni idraulici o per i comandi idraulici a carico sensibile. Messe in serie inviano al comando load sensing la maggiore tra le pressioni di lavoro dell'intero impianto idraulico.

DESCRIPTION

This valve can select the higher pressure between two lines A and B sending the signal to the C port and locking the way to the lower side. It's normally used for auxiliary function such as negative hydraulic brakes, or to drive remote pressure sensing line. In series in a manifold they drive the max pressure of the circuit to the load sensing system.

Codice Ordine	Portata Massima	Pressione Max	Dimensione Porte	Peso
Ordering Code	Max Flow	Max Pressure	Port Size	Weight
A100202.02.00	20 l/min	700 bar	1/4"G	0.4 kg
A100302.01.00	45 l/min	700 bar	3/8"G	0.83 kg
A100402.01.00	60 l/min	700 bar	1/2"G	0.7 kg