

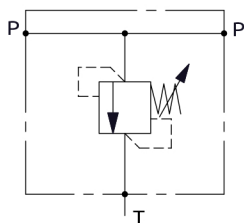

Valvola limitatrice di pressione  
Relief valve

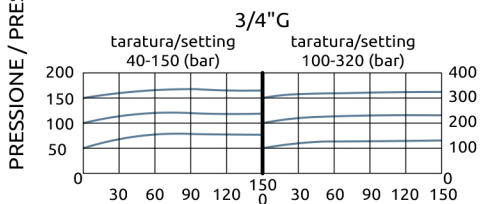

CURVE CARATTERISTICHE  
PERFORMANCE CURVES  
3/8" G - 1/2" G

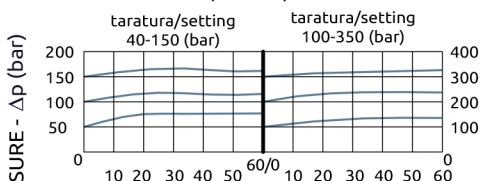

PORTATA / FLOW - Q (l/min)

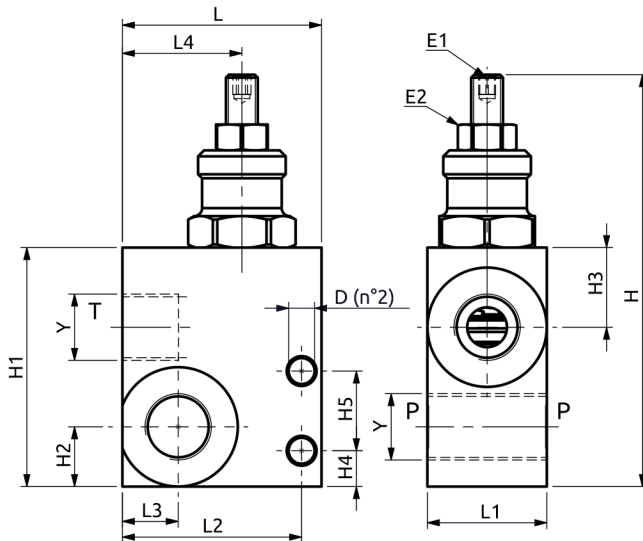

Corpo in acciaio / Steel body

65	40	59	19	40	~167.5	100	29	29	16.5	25	HEX5	ø6.5	HEX17	3/4" G
50	35	45	14	30	~108	65	16	24	10	20	HEX4	ø6.5	HEX13	1/2" G
50	30	45	14	30	~104	60	15	20	9	20	HEX4	ø6.5	HEX13	3/8" G
L	L1	L2	L3	L4	H	H1	H2	H3	H4	H5	E1	D	E2	Y



DESCRIZIONE	DESCRIPTION
Valvola limitatrice di pressione con tenuta ad otturatore, con funzione di protezione del circuito da sovrappressioni. Disponibile con due differenti campi di taratura.	Relief valve in compact steel construction poppet type, for overload protection. Two adjustance pressure ranges.

CODICE ORDINAZIONE PIOMBATURA	SEALING ORDERING CODE
916003	916005
3/8" G - 1/2" G	3/4" G

Codice Ordinazione	Campo di Taratura	Taratura Standard	Incremento per Giro	Portata Massima	Pressione Max	Dimensione Porte	Peso
Ordering Code	Pressure Range	Standard Setting	Pressure Increase	Max Flow	Max Pressure	Port Size	Weight
A010301.01.00	40-150 bar	80 bar	25 bar/turn	50 l/min	400 bar	3/8" G	0.6 kg
A010301.02.00	100-350 bar	250 bar	100 bar/turn	50 l/min	400 bar	3/8" G	0.6 kg
A010401.01.00	40-150 bar	80 bar	25 bar/turn	65 l/min	400 bar	1/2" G	0.8 kg
A010401.02.00	100-350 bar	250 bar	100 bar/turn	65 l/min	400 bar	1/2" G	0.8 kg
A010601.01.00	40-150 bar	80 bar	41 bar/turn	150 l/min	400 bar	3/4" G	1.5 kg
A010601.02.00	100-320 bar	250 bar	69 bar/turn	150 l/min	400 bar	3/4" G	1.5 kg