

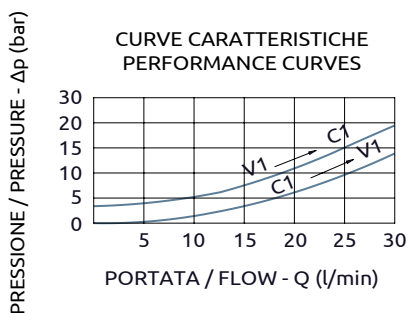

Valvola di blocco doppia pilotata con bullone
Dual pilot operated check valve with hollow screw

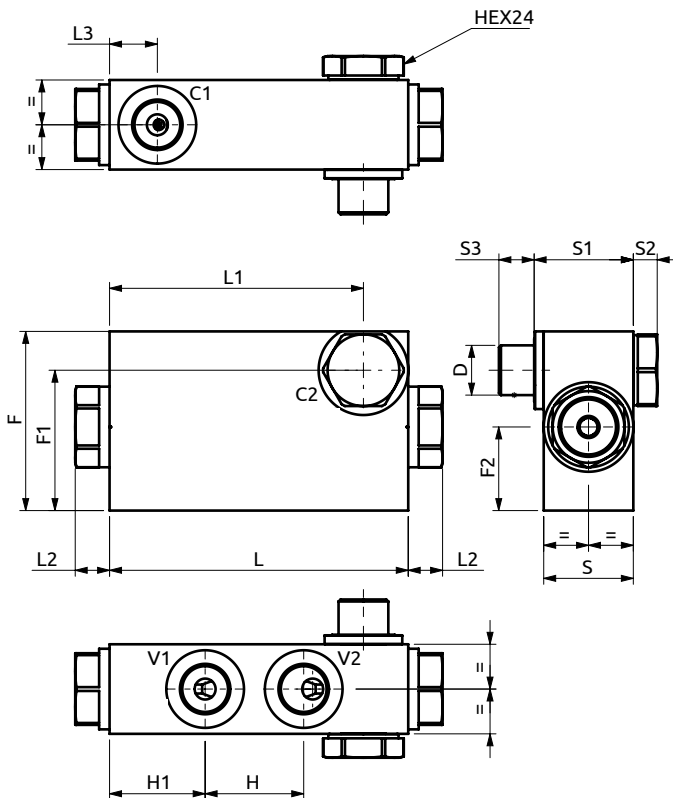
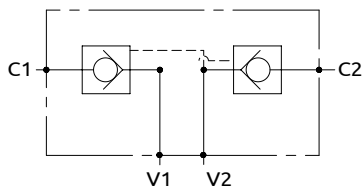

Corpo in alluminio / Aluminium body

B050357.02.00	100	85	11.5	16	30	33.2	8	12	33	32	60	47	28	3/8"G
COD.	L	L1	L2	L3	S	S1	S2	S3	H	H1	F	F1	F2	D



DESCRIZIONE	DESCRIPTION
Permette il flusso libero da V1 verso C1. Idonea al sostentamento di un carico, non al controllo discesa.	The valve allows free flow from V1 to C1. Suitable to hold a load not to control a load lowering.

Codice Ordinazione	Rapporto di Pilotaggio	Pressione di Inizio Apertura	Portata Massima	Pressione Max	Dimensione Porte	Peso
Ordering Code	Pilot Ratio	Cracking Pressure	Max Flow	Max Pressure	Port Size	Weight
B050357.02.00	4.7:1	4.5 bar	30 l/min	350 bar	3/8"G	0.7 kg